

# PNEUMATIC CONTROL VALVES



**Control Solutions**

A pneumatic valve with a small casting body that can easily be mounted in the mini console or tight spaces (without the mounting bracket).

## DAV 1295 PTO/HOIST PNEUMATIC CONTROL VALVES



**Universal Fit**

The PTO is only disengaged when the control lever is moved to the "Full Lower" allowing the PTO to remain engaged for working into an asphalt spreader and similar operations.



**1295-99-01  
PTO/Hoist  
Air Valve**



**1295-99-02  
with Optional  
On/Off  
Pneumatic Valve**



**1295-99-03  
with Optional 1208  
Open/Close  
Tailgate Valve  
& Safety Lock Pin**



*Bottom View*

PTO  
Disengagement  
Zone  
Full Lower  
Position

**Feathering**

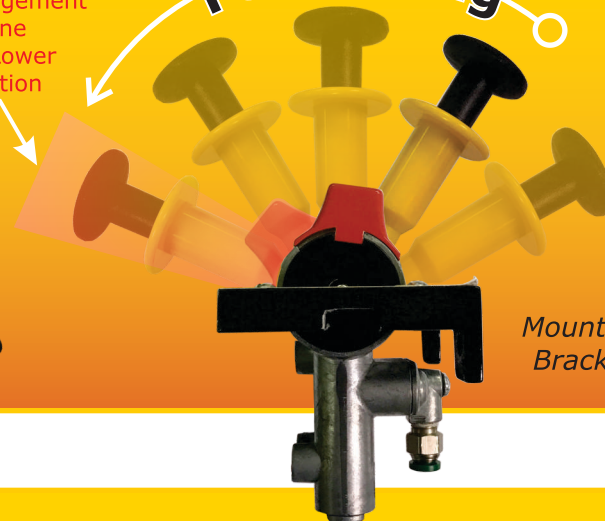

*Mounting  
Bracket*



*Top View*

**The DAV1295 pneumatic Control valve assists in raising and lowering of the hoist.**

- The RED Safety Knob engages & disengages the PTO
- The BLACK / YELLOW lift handle controls the raising, neutral and controlled lowering of pneumatic shift cylinders on various dump pumps (Hoist)
- Automatic mechanical disengagement of the PTO in the "Full Lower" position
- Bright RED LED flashing warning light notifies the operator that the PTO is fully engaged or disengaged
- PTO Safety Knob prevents accidental engagement of the PTO
- 1/8" NPT inlet, exhaust and work ports

**Fully Serviceable**

See **Schematics on flip side of this sheet.**

**Part numbers:**

- **1295-99-01** PTO / Hoist control / Fully Raise Position / Neutral Detent / lower modulating control with PTO Auto-Disengagement
- **1295-99-02** PTO / Hoist Control / Fully Raise Position / Neutral Detent / lower modulating control with PTO Auto-Disengagement / 1201 on off valve.
- **1295-99-03** PTO / Hoist Control / Fully Raise Position / Neutral Detent / Lower modulating control with PTO Auto-Disengagement / 1208 open / close tailgate valve with air logic.

# AIR VALVE INSTALLATION SCHEMATICS

**1295-99-01**

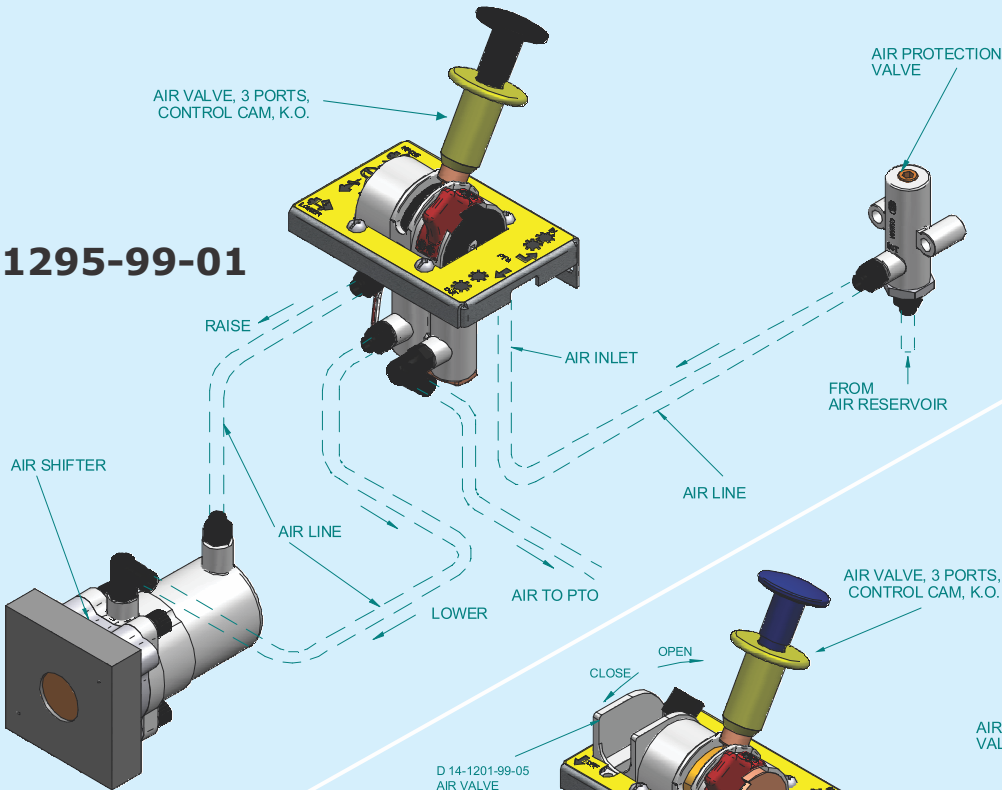

**1295-99-02**

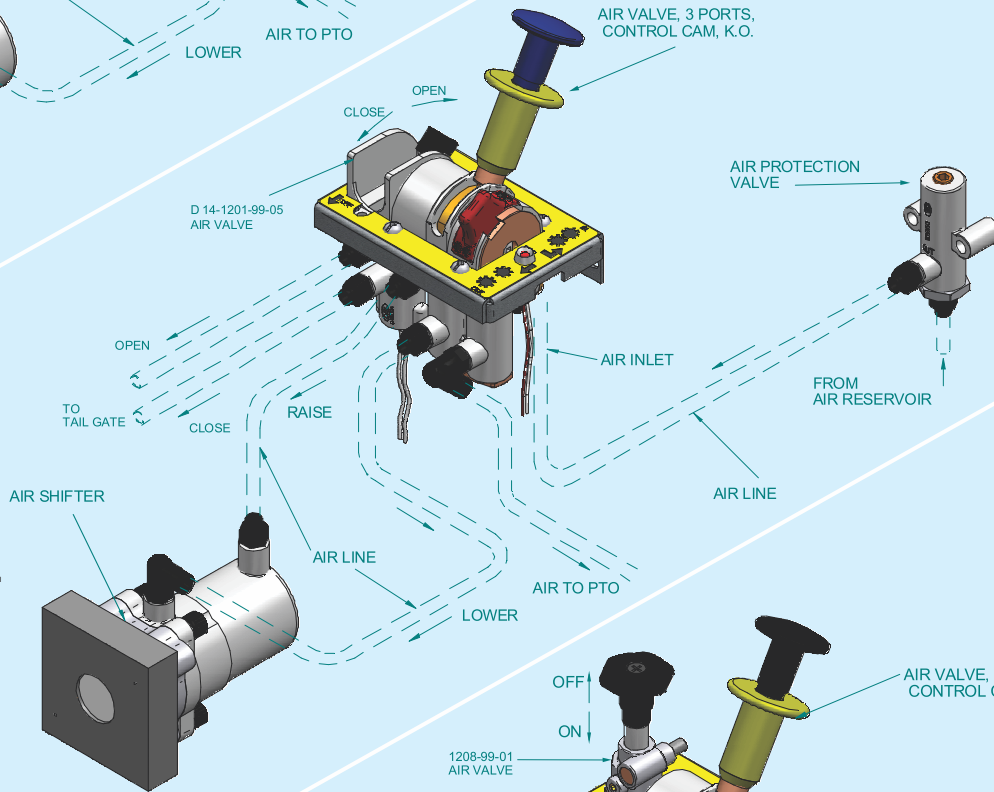

**1295-99-03**

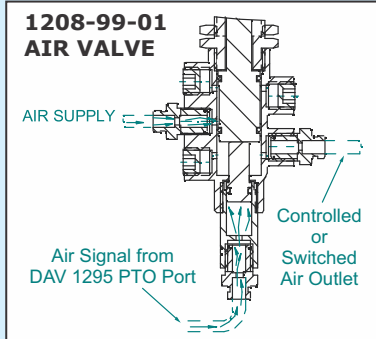
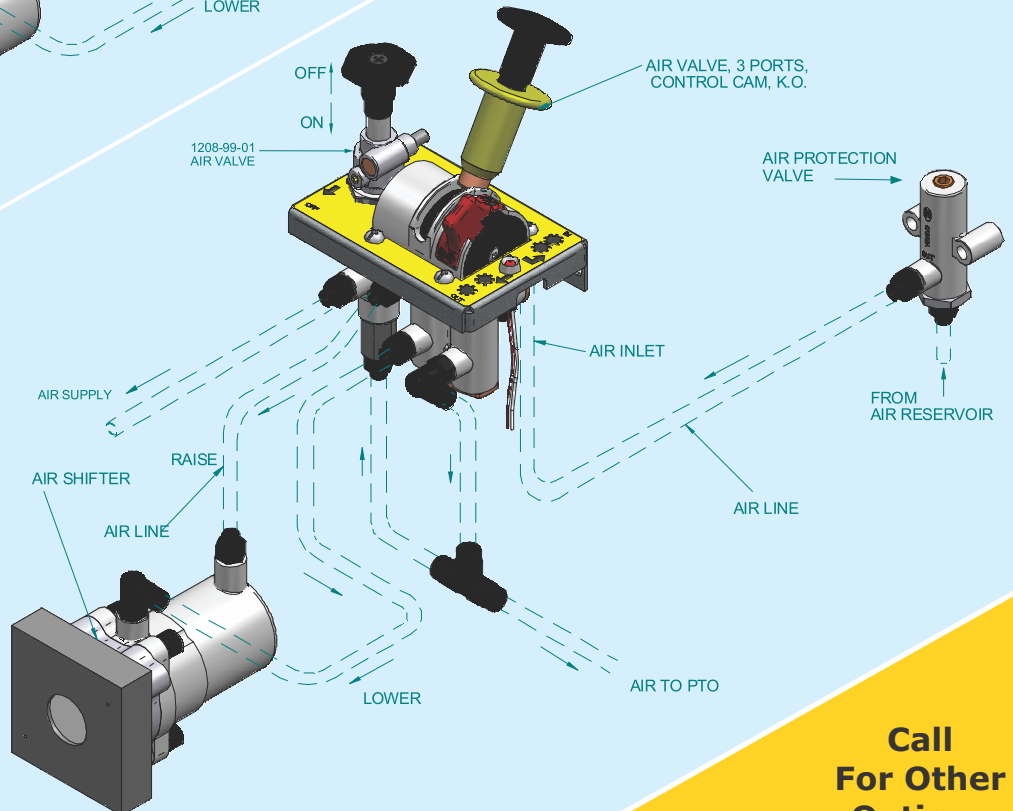

**Call  
For Other  
Options**